

SL 3.6 MCON, Machinery Container

Description:

The SL3.6 Machinery comes in multiple configurations to suit the client's requirements. The container is partitioned into two areas. The larger area accommodates the machinery with the other area fitted out as a workshop and general storage

room or as a HP gas storage area. The machinery area may include two HP compressors and a LP compressor or an HP compressor with diver's heaters. As an option, the machinery container can include a sub-sea tools HPU and a 12 cylinder gas bank in a handling frame.

Illustration:

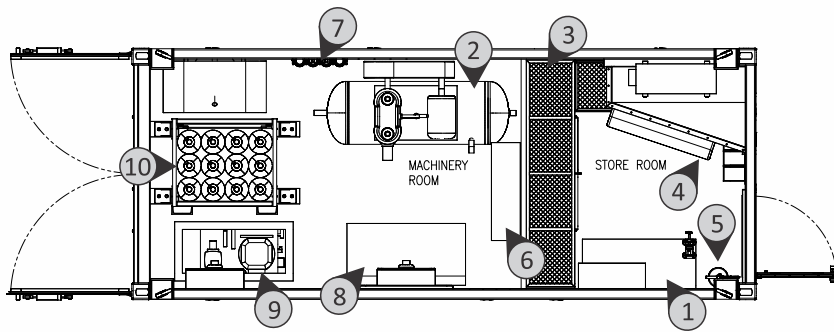

No:	Description:	No:	Description:
1.	Work bench	6.	Solid Room Divider
2.	LP Compressor	7.	Air Filtration
3.	Lockable Storage	8.	HP Compressor (Fan above)
4.	Air-Conditioner	9.	Hydraulic Power Rack (Stowed)
5.	Fire Extinguisher	10.	12 Cylinder Gas Bank (Stowed)

Order Detail:

SL 3.6 MCON HP LP Machinery & Workshop Container	D-CDS-392
SL 3.6 MCON HP DH Machinery & Workshop Container	D-CDS-393
SL 3.6 MCON HP LP Machinery & HP Storage	D-CDS-394
SL 3.6 MCON HP DH Machinery & HP Storage	D-CDS-395
Hydraulic Tools HPU Integrated into Machinery Space	D-CDS-392-01
Secondary Portable HP Compressor Integrated into Machinery Space	D-CDS-392-02

